

Improved R&D Efficiency Through Speedier Method Development (1)

Technical Report vol.33



1. Efficient Method Development Using High-Speed Analysis

Various approaches are available for improving the efficiency of analytical method development. The introduction of high-speed analysis into the method development process for LC and LC/MS is one approach that can directly enhance development efficiency by simply speeding up chromatographic evaluation.

Fig. 1(a) shows an example of a chromatogram obtained using a typical, general-purpose system, while Fig. 1(b) shows a chromatogram exhibiting the equivalent separation as that obtained in Fig. 1(a) using a system capable of high-speed analysis. When developing a method, various combinations of conditions are tested for determination of the eluent solution and selection of the column. In this example, since the higher speed of the analysis allows shortening of the analysis time to about one-seventh that typically required, the total time required for the analytical procedure during method development is shortened to about one-seventh.

(Note) Terminology conventions used in this document are as follows. A system capable of high-speed analysis is referred to as a "high-speed system," and the method developed for use with a high-speed system is a "high-speed method." In addition, a typical general-purpose system is called a "conventional system," and the method used with a conventional system is likewise referred to as a "conventional method."

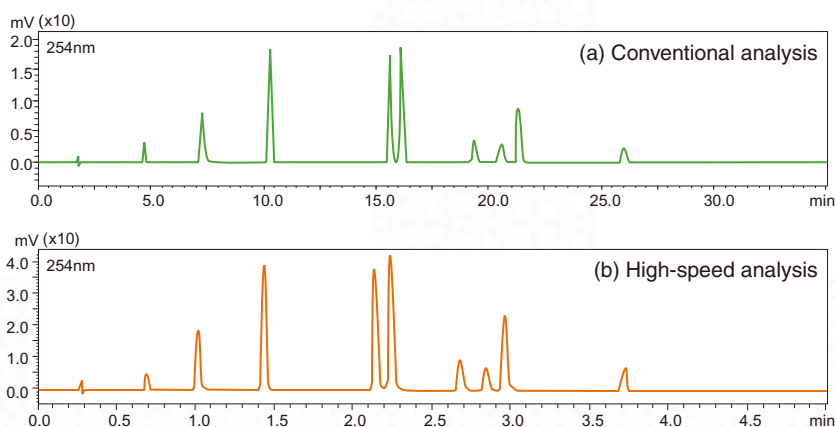

Fig. 1 Comparison of Conventional and High-Speed Analysis of Same Sample

For example, if it takes 100 hours to determine the analytical conditions (a) using a conventional system, 15 hours would be sufficient to obtain the conditions (b) using a high-speed system, thus illustrating the efficiency that could be gained by introducing a high-speed system.

Faster analysis can greatly contribute to improved R&D efficiency when the analysis time per run is long and there are many items to be examined, and furthermore, this approach can reliably provide high-quality method development.

2. Method Transfer to a Conventional System

Using a high-speed system to develop a new method may not necessarily resolve all the relevant issues. It is typical that the developed method must be implemented in the process management and quality control departments of an organization, but these departments might not actually possess high-speed systems. This scenario would apply to a case in which a quality control lab might only have LC systems for conventional analysis. A variety of

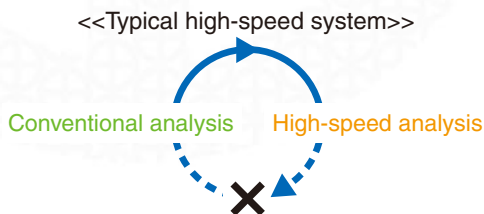

<< Prominence UFLC High-Speed Method Development System>>



Fig. 2 Comparison of Typical High-Speed System and Prominence UFLC High-Speed Method Development System



Fig. 3 Prominence UFLC with LCMS-2020

approaches are being used for implementing method transfer these days, and methods are exchanged not only between departments within a particular company, but also among companies with business relationships. Because many environments are limited to conventional analysis, it is not reasonable to assume that the developed high-speed method will be applicable to all laboratories. This makes it necessary to convert the high-speed method to a conventional method, and because of this, a smooth method transfer process is the key to achieving efficient method development. Therefore not only should improved efficiency of method development be the goal of a high-speed system, it is highly desirable that the high-speed system itself allow effective investigation for method transfer to a conventional method.

3. UFLC High-Speed Method Development System

Shimadzu's newly developed "Prominence UFLC High-Speed Method Development System" is a high-speed/conventional auto switching system specifically designed to support requirements unique to the R&D environment. This system provides all the functionality requirements specified in (1) – (3) below.

- (1) Auto switching between high-speed/conventional analytical columns
→ Shortens investigation time for transfer of high-speed method to conventional method
- (2) Auto switching between eluents
→ Allows rapid investigation of eluents for method optimization
- (3) Accommodates multiple detectors
→ Delivers improved peak identification reliability with the addition of a mass spectrometer

This system promotes more efficient method development using the following workflow:

- (a) Development of a new method begins with an existing conventional method as a reference:

A high-speed method is automatically calculated from the existing method using Method Transfer Program Ver. 2.

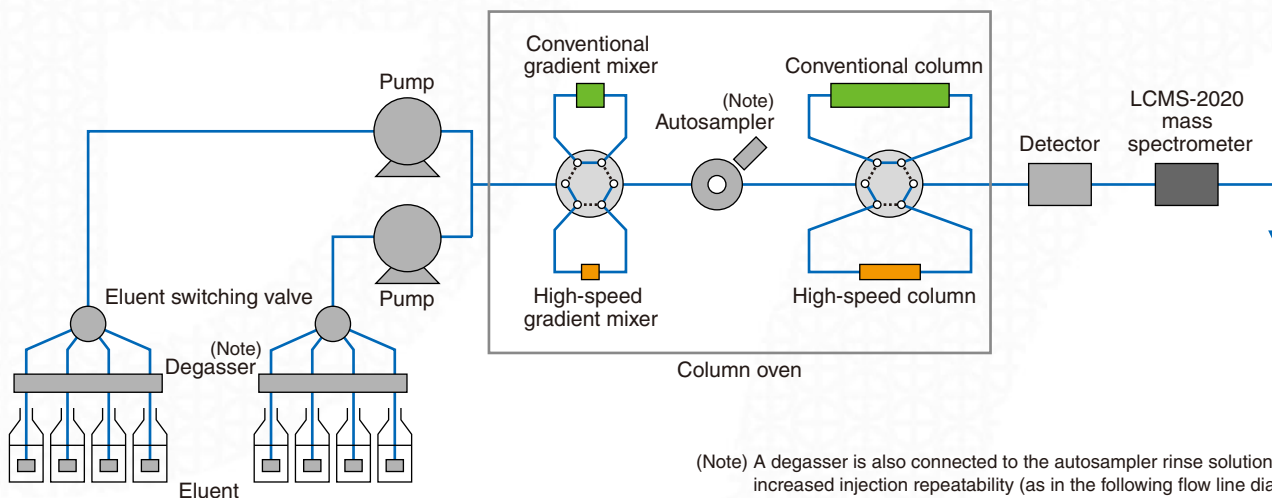

Fig. 4 Prominence UFLC High-Speed Method Development System Flow Line Diagram

- ↓
- (b) New method is developed based on calculated high-speed method:
After calculated high-speed method is introduced to this system, an experimental search is conducted for optimized conditions using high-speed analysis.
- ↓
- (c) High-speed method is established:
Mass spectrometer provides highly accurate peak identification.
- ↓
- (d) Optimized high-speed method is transferred to conventional method:
Conventional method is automatically calculated from optimized high-speed method using Method Transfer Program Ver. 2.
- ↓
- (e) Calculated conventional method is verified empirically:
After applying the conventional method to this system, the separation pattern of the chromatogram obtained using the conventional method is checked.

As shown here, the task of transferring a high-speed method to a conventional method, which has been so difficult in the past, can now be accomplished using a single system (see Fig. 2).

4. System Configurations

Fig. 4 shows the flow line diagram of the Prominence UFLC High-Speed Method Development System. This system merges the

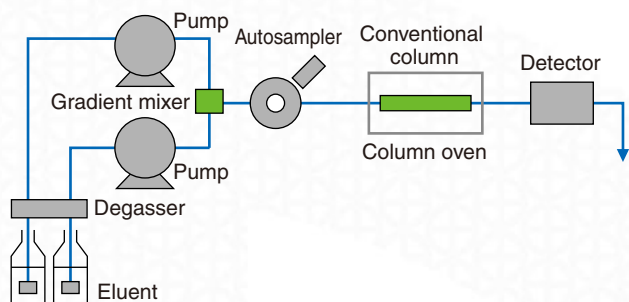

Fig. 5 Conventional System

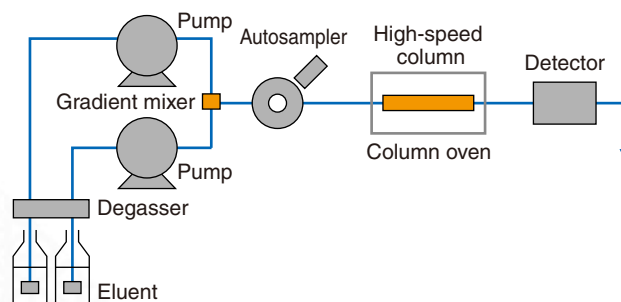

Fig. 6 High-Speed System

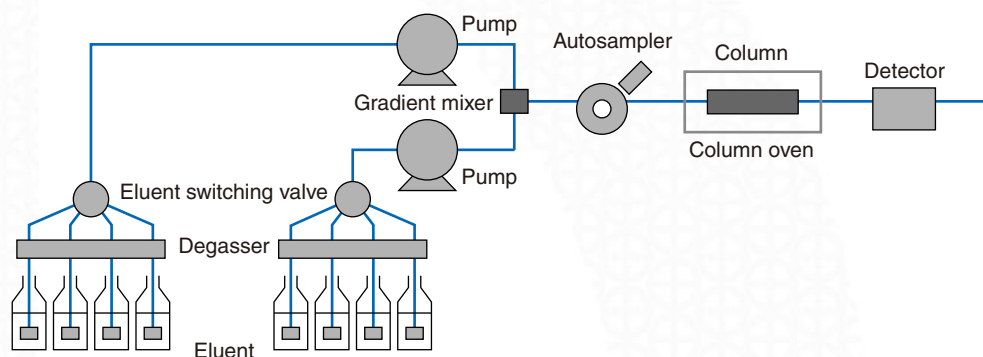

Fig. 7 Eluent Auto Switching System

conventional system of Fig. 5, the high-speed system of Fig. 6, and the eluent auto switching system of Fig. 7, and effectively utilizes the highest level of expandability of the Prominence series.

It is normal to spend a lot of time investigating eluents when developing an analytical method, but since this system is equipped with eluent automatic switching valves, any number of gradient conditions can be sequentially executed using different eluents, allowing an automated search for the optimum conditions.

In addition, this system incorporates a mixer and column for high-speed analysis, as well as a mixer and column for conventional analysis, allowing arbitrary switching between the high-speed analysis flow line and conventional analysis flow line. After establishing the high-speed method using the high-speed flow line, the separation pattern of the chromatogram obtained using the conventional method can be verified by switching the flow to the conventional flow line. Thus, transferring from a high-speed to a conventional method can be accomplished with a single system.

5. Method Transfer Program Ver. 2

The Method Transfer Program Ver. 2 is shown in Fig. 8. After the high-speed method conditions are entered in the left-side input screen (screen for entering the UFLC analytical conditions which are enclosed in the green frame), the simulated analytical conditions for the conventional method are displayed in the blue-framed, right-hand screen after selecting an appropriate column for conventional analysis.

In addition, this program not only provides simulation of the transfer from the high-speed to a conventional method, it also provides the reverse function of transfer from a conventional to the high-speed method. As a result, accumulated resources (methods previously developed for conventional systems) can serve in the development of a high-speed method. The Method Transfer Program Ver. 2, shown in Fig. 8, is available to Shimadzu customers upon request.

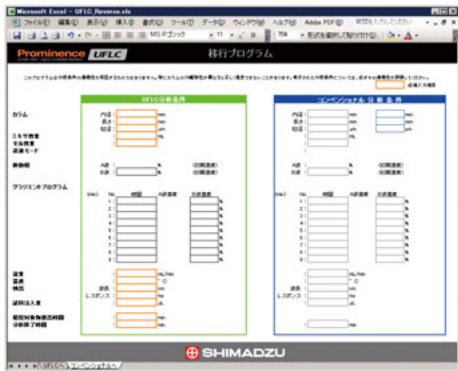

Fig. 8 Method Transfer Program Ver. 2

6. Method Development Case Using This System

A case in which this system is used to conduct method development is presented in Technical Report No. 34 "Improved R&D Efficiency Through Speedier Method Development (2)". That article describes the construction of an analytical method for the simultaneous analysis of non-steroidal anti-inflammatory drugs (NSAIDs), in which eluent selection and optimization of the analytical conditions are achieved quickly for the high-speed Shim-pack XR column (particle size: 2.2 μm). In the final step, the analytical conditions are efficiently transferred for use with a conventional column (particle size: 5 μm).

7. Multiple Columns Addressed with System Expandability

Multiple columns are often examined when investigating method conditions, and the expandability of this method development system effectively supports this type of investigation.

Fig. 9 shows a flow line diagram of an investigative system configuration consisting of multiple columns. Using this system, a total of five columns can be efficiently investigated one after the other.

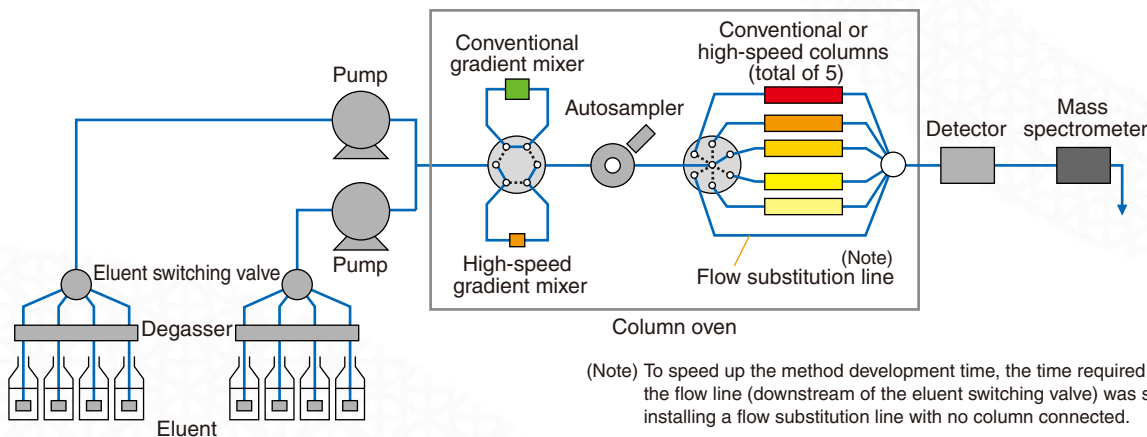

(Note) To speed up the method development time, the time required for substituting the flow line (downstream of the eluent switching valve) was shortened by installing a flow substitution line with no column connected.

Fig. 9 Method Development System for Multiple Column Testing

The information contained in this report is protected by copyright by the publisher, Shimadzu Corporation ("Shimadzu"). The sale, use, reproduction or alteration of this information for any purpose is forbidden without Shimadzu's express written consent, which may be granted or withheld at Shimadzu's sole discretion. Moreover, although the information contained herein has been reviewed, Shimadzu makes no warranty or representation as to its accuracy or completeness. Therefore, if some sort of business or contract is to be entered into in reliance upon this published report and the information contained therein, a Shimadzu business representative must be contacted beforehand for authorization and contractual purposes. This report was created based upon information available to Shimadzu when it was issued, and Shimadzu reserves the right to make revisions to the form and content of this published report without prior notice. First Edition: August, 2009

Founded in 1875, Shimadzu Corporation, a leader in the development of advanced technologies, has a distinguished history of innovation built on the foundation of contributing to society through science and technology. We maintain a global network of sales, service, technical support and applications centers on six continents, and have established long-term relationships with a host of highly trained distributors located in over 100 countries. For information about Shimadzu, and to contact your local office, please visit our Web site at www.shimadzu.com



JQA-0376



SHIMADZU CORPORATION. International Marketing Division
 3. Kanda-Nishikicho 1-chome, Chiyoda-ku, Tokyo 101-8448, Japan
 Phone: 81(3)3219-5641 Fax: 81(3)3219-5710
 URL <http://www.shimadzu.com>